

5.0 x 3.2 mm Glass Seal SMD Crystal – XS Type

FEATURE

- Typical 5.0 x 3.2 x 1.3 mm full ceramic SMD package.
- 12 mm width Tape & Reel package for automatic assembly.
- Packing: Tape & Reel, 1000/3000 pcs per Reel.

TYPICAL APPLICATION

- Automotive
- Notebook, Computer Peripherals, Hard Disk
- MP3 Player, Audio & Visual

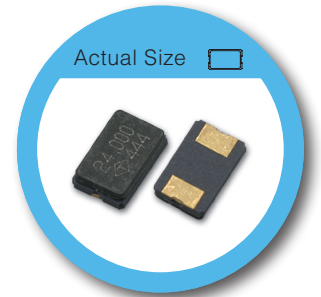

RoHS Compliant Standard

DIMENSION (mm)

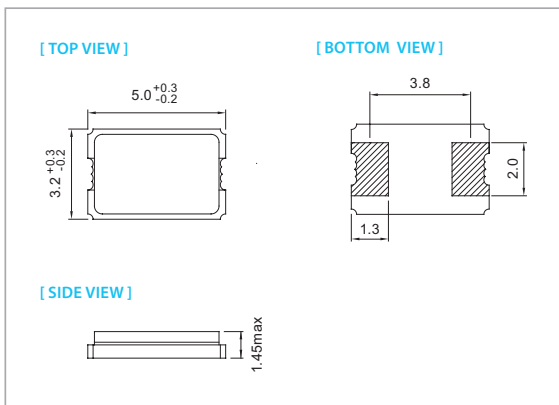

SOLDER PAD LAYOUT (mm)

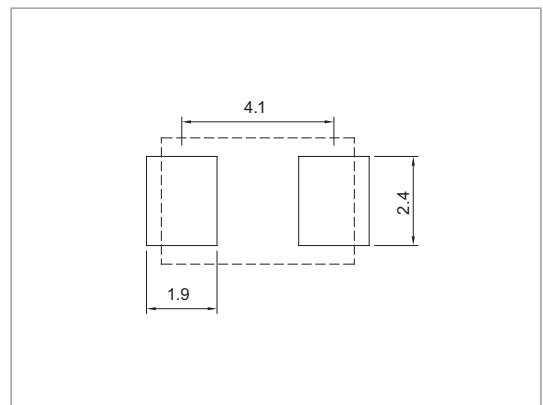

ELECTRICAL SPECIFICATION

Parameter	Min.	Typical	Max.	Unit
Storage Temp. Range	-55	-	125	°C
Level of Drive	-	10	500	µw
Shunt Capacitance (Co)	-	-	7.0	pF
Insulation Resistance	500 MΩ @ DC100V	-	-	
Aging		±5.0		ppm / year

Standard frequencies are frequencies which the crystal has been designed and does not imply a stock position.

EQUIVALENT SERIES RESISTANCE (E.S.R)

TYPE FREQUENCY	MODE	E.S.R
10 MHz ≤ Freq. < 16 MHz	A1	<150Ω
16 MHz ≤ Freq. < 20 MHz	A1	<100Ω
20 MHz ≤ Freq. < 30 MHz	A1	< 70Ω
30 MHz ≤ Freq. < 50 MHz	A1	< 50Ω

FREQ. STABILITY vs. TEMP. RANGE

Temp. (°C)	ppm			
	±5	±10	±15	±20
-10 ~ +60	△	○	○	○
-20 ~ +70	×	△	○	○
-40 ~ +85	×	△	△	○

* ○ : Available △:Conditional X: Not available