

7.0 x 5.0 mm SMD PECL/LVDS Voltage Controlled Crystal Oscillator – VT Type

FEATURE

- Typical 7.0 x 5.0 x 1.6 mm 6 pads ceramic SMD package.
- Tight symmetry (45 to 55%) available.
- Wide frequency control range.
- Complementary Output.
- Packing: Tape & Reel, 1000/3000pcs per Reel.

TYPICAL APPLICATION

- Set-top Box, HDTV
- Wimax/WLAN
- xDSL/ VoIP, Cable modem

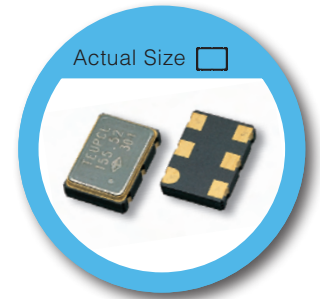

RoHS Compliant Standard

DIMENSION (mm)

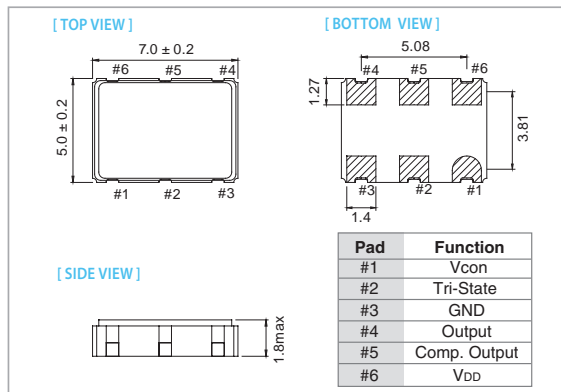

SOLDER PAD LAYOUT (mm)

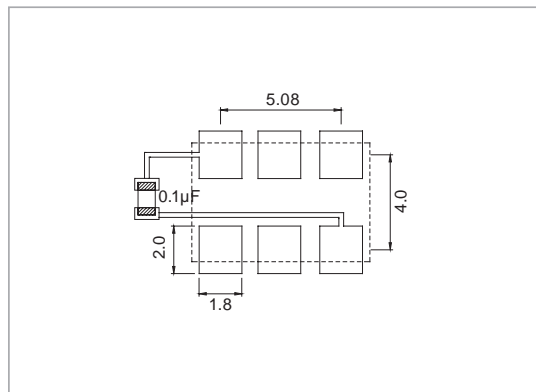

ELECTRICAL SPECIFICATION

Parameter	PECL				LVDS				Unit
	3.3 V		2.5V		3.3 V		2.5V		
	Min.	Max.	Min.	Max.	Min.	Max.	Min.	Max.	
Supply Voltage Variation (VDD) 5%	3.135	3.465	2.375	2.625	3.135	3.465	2.375	2.625	V
Frequency Range	1.5	200	65	200	1.5	200	65	200	MHz
Standard Frequency	77.76, 106.25, 122.88, 125, 155.52, 156.25, 200								
Absolute Pulling Range (APR)	±50	—	±50	—	±50	—	±50	—	ppm
Control Voltage Range	0.3	3.0	0	2.5	0.3	3.0	0	2.5	V
Supply Current	1.5 MHz ≤ Fo < 65 MHz		65 MHz ≤ Fo ≤ 200 MHz		1.5 MHz ≤ Fo < 65 MHz		65 MHz ≤ Fo ≤ 200 MHz		mA
	—	75	—	75	—	45	—	45	
	—	100	—	100	—	80	—	80	
Output Level	Output High (Logic"1")		Output Low (Logic"0")		Output High (Logic"1")		Output Low (Logic"0")		V
	2.275	—	1.475	—	—	1.6	—	1.6	
	—	1.68	—	1.095	0.9	—	0.9	—	
Transition Time: Rise/Fall Time+	—	1.0	—	1.0	—	1.0	—	1.0	nSec
Start Time	—	3	—	3	—	3	—	3	mSec
Tri-State (input to Pin 2, Enable Low)									
Enable	—	0.3 VDD	—	0.3 VDD	—	0.3 VDD	—	0.3 VDD	V
Disable	0.7 VDD	—	0.7 VDD	—	0.7 VDD	—	0.7 VDD	—	
Linearity	—	10	—	10	—	10	—	10	%
Modulation Bandwidth (BW)	25	—	25	—	25	—	25	—	KHz
Input Impedance	50	—	50	—	50	—	50	—	KΩ
RMS Phase Jitter (Integrated 12 KHz-20 MHz)									
	Fo < 100 MHz		100 MHz ≤ Fo < 125 MHz		125 MHz ≤ Fo < 150 MHz		150 MHz ≤ Fo		pSec
	—	1	—	1	—	1	—	1	
	—	0.7	—	0.7	—	0.7	—	0.7	
	—	0.5	—	0.5	—	0.5	—	0.5	
	—	0.3	—	0.3	—	0.3	—	0.3	
Aging	—	±3	—	±3	—	±3	—	±3	ppm
Storage Temp. Range	-55	125	-55	125	-55	125	-55	125	°C

Standard frequencies are frequencies which the crystal has been designed and does not imply a stock position.

+ Transition times are measured between 20% and 80% of VDD.

FREQ. STABILITY vs. TEMP. RANGE

Temp. (°C)	ppm	
	±25	±50
-10 ~ +60	△	○
-20 ~ +70	△	○
-40 ~ +85	×	○

* ○ : Available △ : Conditional X : Not available

* Inclusive of calibration @ 25 °C, operating temperature range, input voltage variation, load variation, aging (1st year), shock, and vibration