

14.3 x 8.7 mm Voltage Controlled Temperature Compensated Crystal Oscillator – TK Type

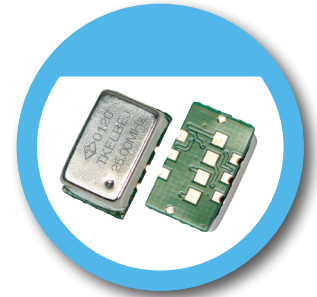

FEATURE

- Typical 14.3 x 8.7 x 4.9 mm.
- Metal cover, FR-4 PCB based.
- Output: TTL/CMOS or Clipped Sine Wave.
- Low current option (2mA for Clipped Sine Wave o/p).
- VCTCXO available.
- Packing: Tape & Reel, 500 pcs per Reel.

TYPICAL APPLICATION

- Large-Scale equipment
- WLAN/WIMAX
- Mobile Phone

RoHS Compliant Standard

DIMENSION (mm)

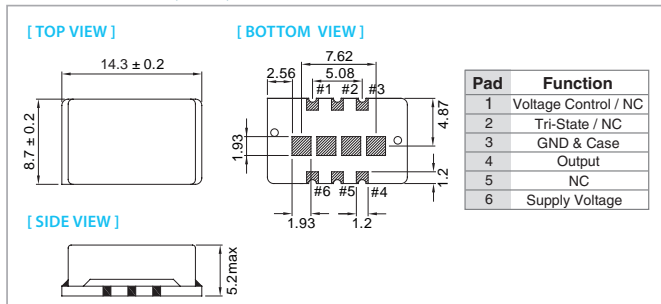

SOLDER PAD LAYOUT (mm)

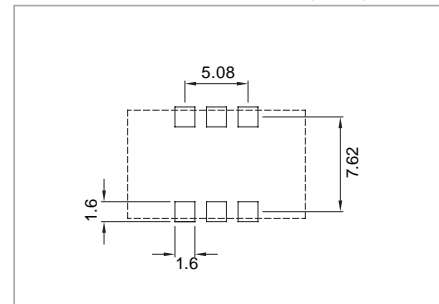

ELECTRICAL SPECIFICATION

Parameter	5.0 V		3.3 V		Unit	
	Min.	Max.	Min.	Max.		
Supply Voltage Variation (V _{DD}) 5%	4.75	5.25	3.135	3.465	V	
Frequency Range	5	40	5	40	MHz	
Standard Frequency (for CMOS)	5, 6.4, 8, 8.192, 10, 12.5, 12.8, 16, 16.384, 19.44, 25					
Standard Frequency (for Clipped Sine)	8.192, 10, 12.5, 12.8, 16, 16.384, 19.44, 25				ppm	
Frequency Tolerance*	-	±2.0	-	±2.0		
Frequency Stability					ppm	
Vs Supply Voltage (±5%) change (for CMOS)	-	±0.3	-	±0.3		
Vs Load (±10%) change	-	±0.2	-	±0.2		
Vs Aging	-	±1.0	-	±1.0		
Supply Current (CMOS output)	-	6	-	6	mA	
Supply Current (Clipped Sine Wave)	-	3.5	-	3.5		
Output Level (CMOS)	Output High (Logic "1")	90%V _{DD}	-	90%V _{DD}	V	
	Output Low (Logic "0")	-	10%V _{DD}	10%V _{DD}		
	Duty	45	55	45	55	%
Output Level (Clipped Sine Wave)		0.8	-	0.8	V _{p-p}	
Load (CMOS)	15pF		15pF			
Load (Clipped Sine Wave)	10 KΩ // 10pF		10 KΩ // 10pF			
Control Voltage Range (VCTCXO)	0.5	2.5	0.5	2.5	V	
Pulling Range (VCTCXO)	±5.0	-	±5.0	-	ppm	
V _c Input Impedance (VCTCXO)	100	-	100	-	KΩ	
Phase Noise @ 12.8 MHz	100 Hz	-120	-120	-120	dBc/Hz	
	1 KHz	-140	-140	-140		
	10 KHz	-148	-148	-148		
Start time	-	2	-	2	mSec	
Tri-State (option)	Disable	-	0.3V _{DD}	-	V	
	Enable	0.7V _{DD}	-	0.7V _{DD}		
Storage Temp. Range	-55	125	-55	125	°C	

Standard frequencies are frequencies which the crystal has been designed and does not imply a stock position.

*Frequency at 25°C, 1 hour after reflow.

FREQ. STABILITY vs. TEMP. RANGE

Temp. (°C)	ppm						
	±0.05	±0.1	±0.14	±0.2	±0.28	±0.37	±0.5
0 ~ +55	○	○	○	○	○	○	○
-10 ~ +60	○	○	○	○	○	○	○
-20 ~ +70	△	○	○	○	○	○	○
-40 ~ +85	×	×	×	△	○	○	○

* ○: Available △:Conditional X: Not available